

Twin 3 Gallon Automatic Electric Coffee Urn

ITEM#

PROJECT

DATE



Model U3*

Dimensions: 32.4" H x 34.5" W x 21" D
(82.3cm H x 87.6cm W x 53.3cm D)

Features

Automatic Electric Coffee Urn

- Brews 16.3 to 18.8 gallons (61.7 to 71.2 litres) of perfect coffee per hour.
- Unique design assures extremely low evaporation loss to maintain the brew at its flavorful peak.
- Large water tank—over 20 gallons.
- Draw off hot water during brewing cycle without affecting coffee quality.
- Half-batch option.
- Top mounted components for ease of service.
- All stainless steel construction.
- International electrical configurations available.

For current specification sheets and other information, go to www.bunn.com.

* International models may vary in appearance.

Related Products

Easy Clear® EQ-12-TL

Product No. : 30345.1001

Dimensions:

20 $\frac{1}{8}$ " H x 3 $\frac{5}{8}$ " W x 4 $\frac{17}{32}$ " D

51.12 cm H x 9.21 cm W x 11.51 cm D



SRU Paper Filters

Product No. : 20109.0000

Packed per case: 250

Dimensions: 7" Base x 5 $\frac{1}{4}$ " Sidewall

17.78 cm Base x 13.34 cm Sidewall



U3 Drip Tray (Optional)

Product No. : 07284.000

All Stainless Steel



Easy Clear® ED-12-TL

Product No. : 30201.0001

Dimensions:

23 $\frac{3}{4}$ " H x 5 $\frac{3}{16}$ " W x 5 $\frac{3}{16}$ " D

60.33 cm H x 13.18 cm W x 13.18 cm D

Easy Pour® black decanter

Product No. : 06100.0101

Quantity: 1

(also packaged in quantities of 2, 3, 6, 12, & 24)



Easy Pour® orange decanter (for decaf)

Product No. : 06101.0101

Quantity: 1 (also packaged in quantities of 2, 3, 6, 12, & 24)

Model

Agency Listing

U3



Dimensions & Specifications

Model	Product #	Volts	Amps	Tank Heater Watts	Total Watts	Brewing Capacity	Cu. Ft.	Shipping Weight	Cord Attached
U3 (SS)	20500.0000	120/208	28	5750	5825	16.3 gal./hr.	18	103 lbs.	No
U3 (SS)	20500.0001	120/240	28	6650	6725	18.8 gal./hr.	18	103 lbs.	No

Note: SS=Single Service

Brewing capacity: based upon incoming water temp of 60°F (140°F rise) per 1/2 gallon brew time of 4 minutes.

Models listed as 120/208V or 120/240V must be connected to 208V or 240V electrical service respectively. Please refer to the installation manual.

Electrical: Model requires 3-wires plus ground service rated 120/240V, single phase, 60 Hz.

Plumbing: 20-90 psi (138-621 kPa). Supplied with 3/8" OD male flare fitting.

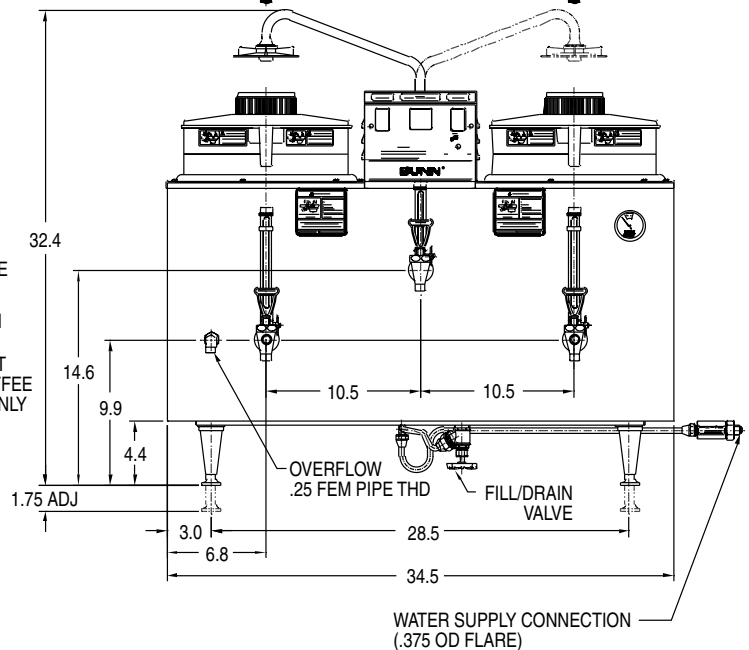
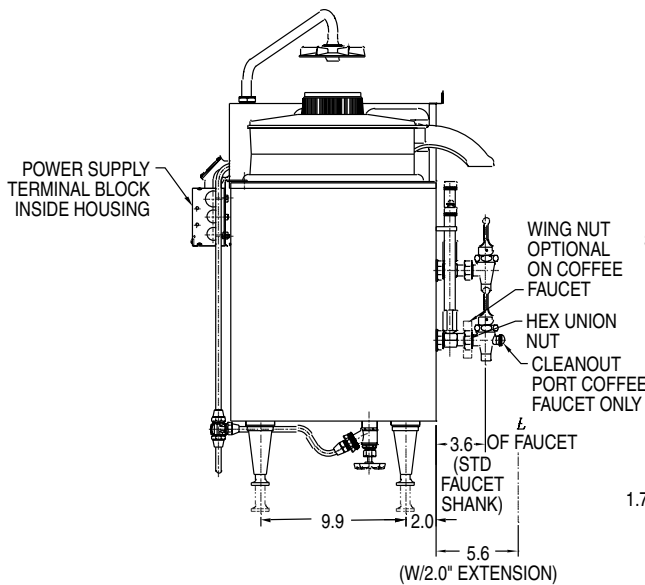
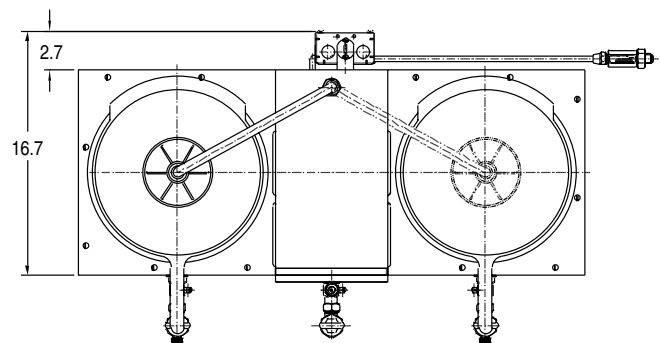
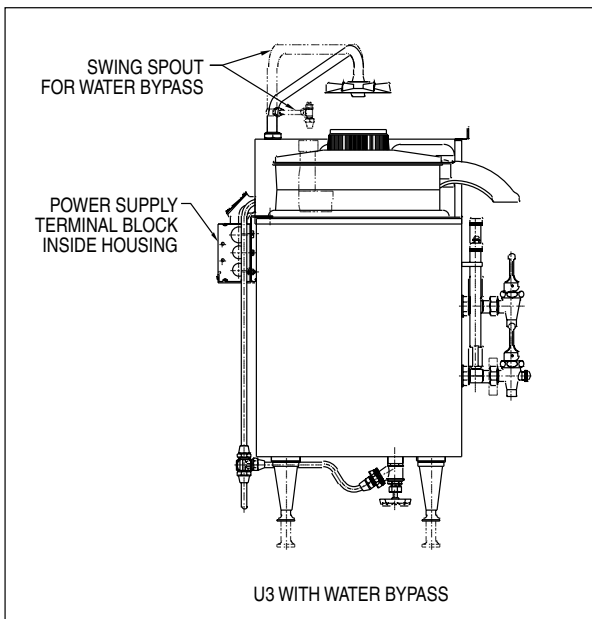

BUNN Corporation - 1400 Stevenson Drive Springfield, Illinois 62703 • 800-637-8606 • 217-529-6601 • Fax 217-529-6644 • www.bunn.com

BUNN® practices continuous product research and improvement. We reserve the right to change specifications and product design without notice. Such revisions do not entitle the buyer to corresponding changes, improvements, additions or replacements for previously purchased equipment.

All dimensions shown in inches. Bunn Corporation owns all copyrights relating to materials in this publication. Please contact Bunn Corporation to request permission to reproduce any portion of this publication.