

# BUNN® Powder Autofill Gourmet Ice® System with 2 hoppers

## Features

### Gourmet Ice® System

- Two large hoppers hold 2 gallons of frozen drinks each.
- Dry product hoppers (5 lb. capacity each) are easy to remove & fill.
- Product and water mix control, adjustable with motor speed from 15 to 90 RPM.
- Lighted display increases sales with product merchandising.
- Refills at a rate of approximately 1.1 fluid ounces per second.
- Flashing light alerts that powder is low.
- 2-year warranty on compressor.
- Available in white or black decor.
- Sanitation listed by ETL to NSF Standard 18 (includes dairy & alcohol) and safety listed by ETL to UL Standard (UL 471) and CSA Standard (C22.2 No. 120).



Model CDS-2 PAF\*

\* International models may vary in appearance.

## Related Products

For available variations to some BUNN products, please contact your BUNN sales representative.



Clear plastic hoppers pull out easily to refill powdered product.



Entire autofill unit slides back so that product hoppers can be lifted out for cleaning.

ITEM#

PROJECT

DATE

International Model

CDSA-2 PAFA

Model

CDS-2 PAF

## BUNN®

**Corporate Offices**  
1400 Stevenson Drive  
Springfield, Illinois 62703  
**Phone**  
800-637-8606  
217-529-6601  
**Fax**  
217-529-6644  
**Technical Services**  
800-286-6070  
**Internet**  
<http://www.bunnomatic.com>

**Western Regional Office**  
16431 Carmenita Road,  
Cerritos, California 90701  
**Phone**  
562-926-0764  
**Fax**  
562-926-0858

**Canadian Office**  
280 Industrial Parkway South  
Aurora, Ontario, L4G 3T9  
**Phone**  
905-841-2866  
**Fax**  
905-841-2775

Patents Apply



## Dimensions & Specifications

Model	Product #	Volts	Amps	Capacity	Cu Ft.	Shipping Weight	Cord Attached
CDS-2 PAF (White)	27000.0033	120	11.5	5 lbs. dry product	21.5	185 lbs. (84.0 kg) <i>See Note</i>	Yes
CDS-2 PAF (Black)*	27000.0035	120	11.5	5 lbs. dry product	21.5	185 lbs. (84.0 kg) <i>See Note</i>	Yes
<i>Note-Includes the following:</i>							
(1) CDS-2 PAF Base	(28510.0002)	120	9.5	n/a	10.7	120 lbs. (54.5 kg)	Yes
(1) 2-PAF Hopper Group	(28485.0025)	n/a	n/a	2 @ 2 gallons	6.1	25 lbs. (11.4 kg)	n/a
(2) PAF Units	(29500.0000)	120	1.0	1 @ 5 lbs. dry	2.7	20 lbs. (9.1 kg)	Yes

\* Model is a non-stock item.

Electrical: Model requires 2-wires plus ground service rated 120V, single phase, 60 Hz.

Plumbing: 20-90 psi (138-621 kPa). Machine supplied with 1/4" male flare fitting.

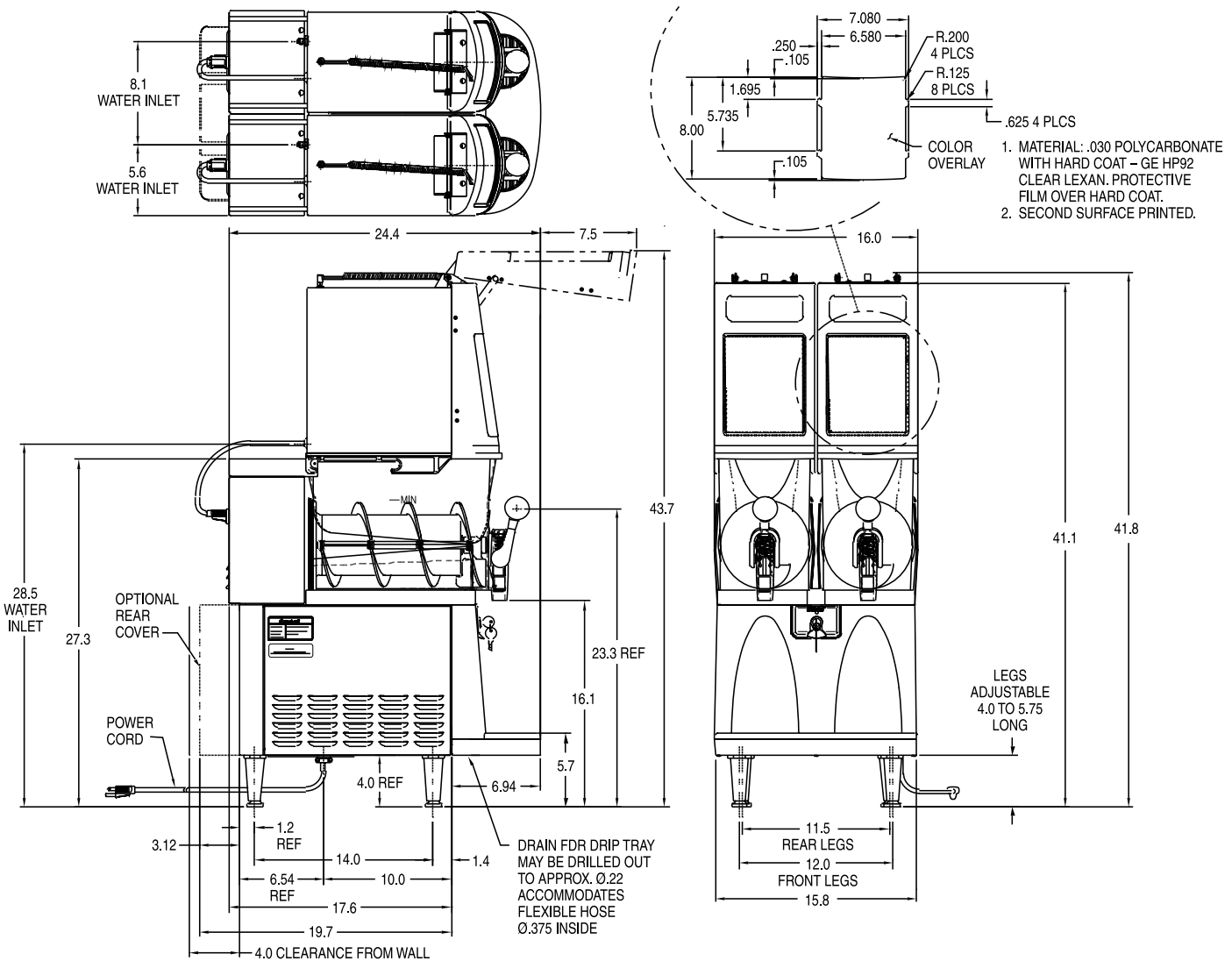

All dimensions shown in inches.