

# BUNN®

## *G9 HD* *G9T HD*

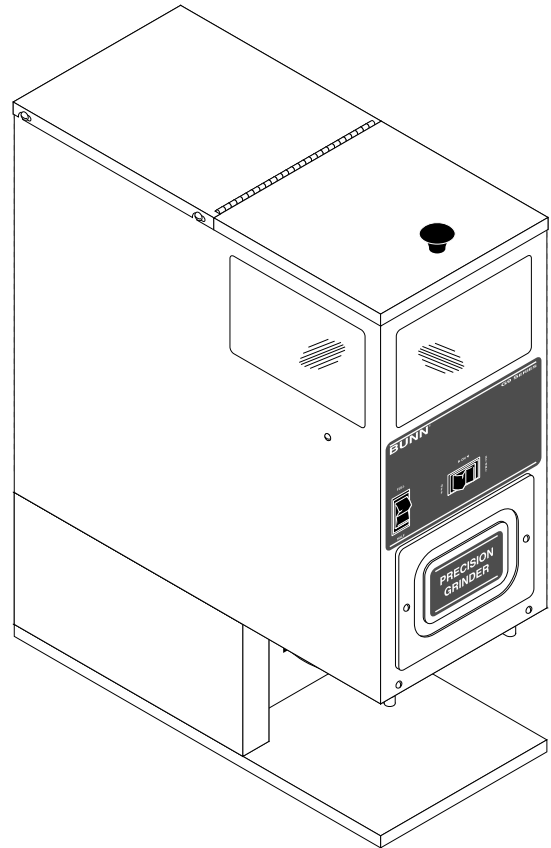
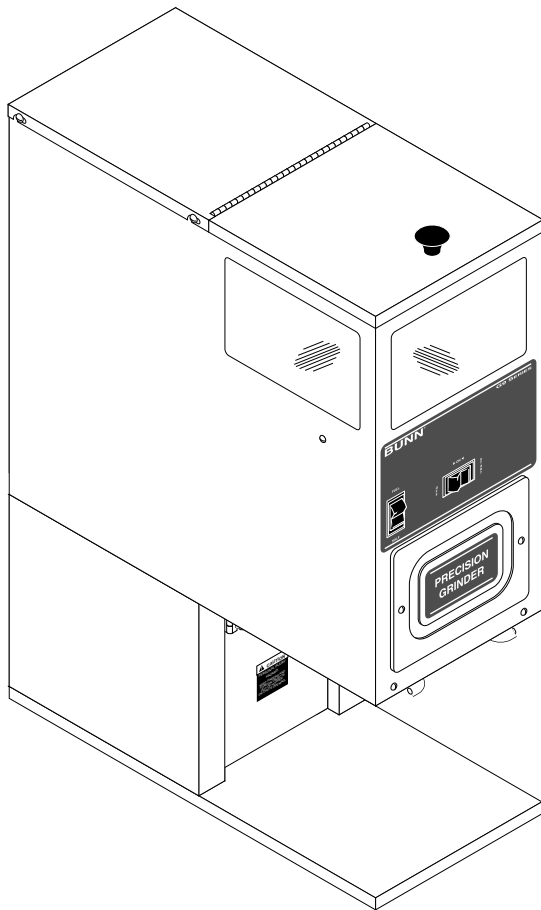

## OPERATING & SERVICE MANUAL

**BUNN-O-MATIC CORPORATION**

POST OFFICE BOX 3227

SPRINGFIELD, ILLINOIS 62708-3227

PHONE: (217) 529-6601 FAX: (217) 529-6644

# CONTENTS

Introduction -----	2
Warranty -----	2
User Notices -----	3
Electrical Requirements -----	3
Initial Set Up -----	3
Operating Controls -----	3
Cleaning -----	4
Coffee Grinding -----	4
Adjustments -----	4
Troubleshooting -----	6
Service -----	8
Wiring Diagram -----	14

## INTRODUCTION

This equipment will store up-to nine pounds of whole bean coffee and grind it to a preset grind and amount into an awaiting funnel and filter from most commercial drip coffee brewers. The equipment is only for indoor use on a sturdy counter or shelf. Adequate space must be available above the grinder to raise the lid when adding beans. Use only with whole bean coffee.

The grind is preset at the factory to **drip** specifications as set forth by the United States Department of Commerce and adopted by the Coffee Brewing Center of the Pan American Coffee Bureau. Adjustments may be made to alter both the amount and grind from the factory setting.

## WARRANTY

Bunn-O-Matic Corp. (“Bunn”) warrants the equipment manufactured by it to be commercially free from defects in material and workmanship existing at the time of manufacture and appearing within one year from the date of installation. In addition:

- 1.) Bunn warrants electronic circuit and/or control boards to be commercially free from defects in material and workmanship for two years from the date of installation.
- 2.) Bunn warrants the compressor on refrigeration equipment to be commercially free from defects in material and workmanship for two years from the date of installation.
- 3.) Bunn warrants that the grinding burrs on coffee grinding equipment will grind coffee to meet original factory screen sieve analysis for three years from date of installation or for 30,000 pounds of coffee, whichever comes first.

This warranty does not apply to any equipment, component or part that was not manufactured by Bunn or that, in Bunn’s judgement, has been affected by misuse, neglect, alteration, improper installation or operation, improper maintenance or repair, damage or casualty.

**THE FOREGOING WARRANTY IS EXCLUSIVE AND IS IN LIEU OF ANY OTHER WARRANTY, WRITTEN OR ORAL, EXPRESS OR IMPLIED, INCLUDING, BUT NOT LIMITED TO, ANY IMPLIED WARRANTY OF EITHER MERCHANTABILITY OR FITNESS FOR A PARTICULAR PURPOSE.** The agents, dealers or employees of Bunn are not authorized to make modifications to this warranty or to make additional warranties that are binding on Bunn. Accordingly, statements by such individuals, whether oral or written, do not constitute warranties and should not be relied upon.

The Buyer shall give Bunn prompt notice of any claim to be made under this warranty by telephone at (217) 529-6601 or by writing to Post Office Box 3227, Springfield, Illinois, 62708-3227. If requested by Bunn, the Buyer shall ship the defective equipment prepaid to an authorized Bunn service location. If Bunn determines, in its sole discretion, that the equipment does not conform to the warranty, Bunn shall repair the equipment with no charge for parts during the warranty period and no charge for labor by a Bunn Authorized Service Representative during the warranty period. If Bunn determines that repair is not feasible, Bunn shall, at its sole option, replace the equipment or refund the purchase price for the equipment.

**THE BUYER’S REMEDY AGAINST BUNN FOR THE BREACH OF ANY OBLIGATION ARISING OUT OF THE SALE OF THIS EQUIPMENT, WHETHER DERIVED FROM WARRANTY OR OTHERWISE, SHALL BE LIMITED, AS SPECIFIED HEREIN, TO REPAIR OR, AT BUNN’S SOLE OPTION, REPLACEMENT OR REFUND.**

In no event shall Bunn be liable for any other damage or loss, including, but not limited to, lost profits, lost sales, loss of use of equipment, claims of Buyer’s customers, cost of capital, cost of down time, cost of substitute equipment, facilities or services, or any other special, incidental or consequential damages.

## USER NOTICES

Carefully read and follow all notices on the grinder and in this manual. They were written for your protection. All notices on the grinder are to be kept in good condition. Replace any unreadable or damaged labels.



#05876.0000

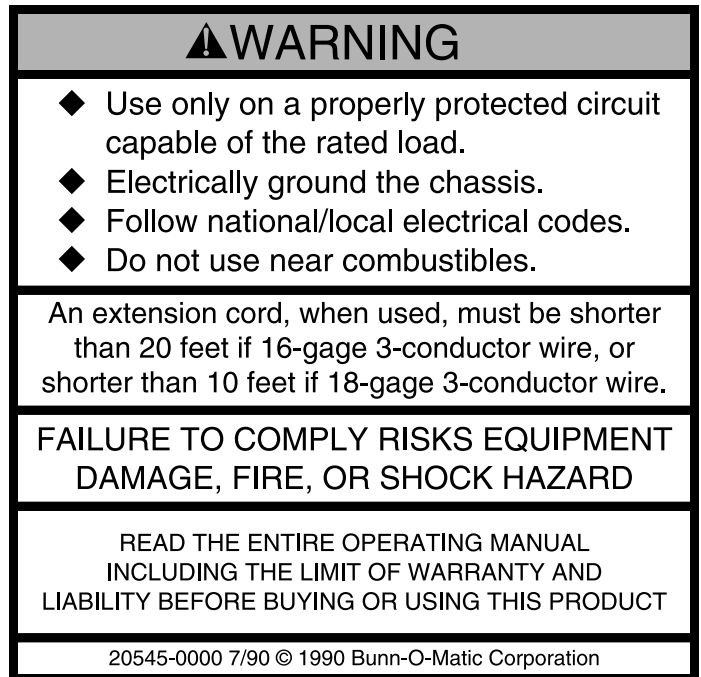

#20545.0000

## ELECTRICAL REQUIREMENTS

This grinder has an attached cordset and requires 2-wire, grounded service rated 120 volts ac, 15 amp, single phase, 60 Hz or 2 wire, grounded service rated 220-240 volts ac, 4.7 amp, single phase, 50 Hz.

## INITIAL SET UP

1. Open the top lid. Clear all foreign objects and shipping materials from the hopper compartment and the entrance to the grind chamber.
2. Fill hopper compartment with whole bean coffee. (Capacity 9 pounds). The grinder is now ready for use.

## OPERATING CONTROLS

### Off/On/Start Switch

**OFF** - (left position)

Placing the switch in this position stops the operation of the grinder.

**ON** - (center, resting position)

The switch will return to this position after a grind cycle has begun and will remain in this position after grinding has ceased.

**START** - (right, momentary position)

Placing the switch in this position initiates a timed grind cycle.

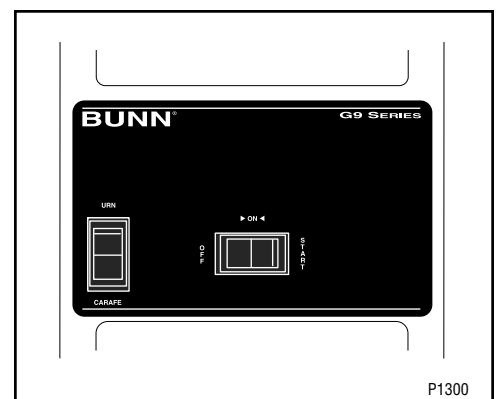

### Batch Selector Switch (Optional)

**URN** - Switching to this position allows the correct amount of beans to be dispensed when grinding a large batch.

**CARAFE** - Switching to this position allows the correct amount of beans to be dispensed when grinding a small batch.

## CLEANING

The use of a damp cloth rinsed in any mild, non-abrasive, liquid detergent is recommended for cleaning all surfaces on Bunn-O-Matic equipment. Care should be taken not to scratch the windows with any abrasive material. Regular cleaning will keep your grinder looking new for years.

## COFFEE GRINDING

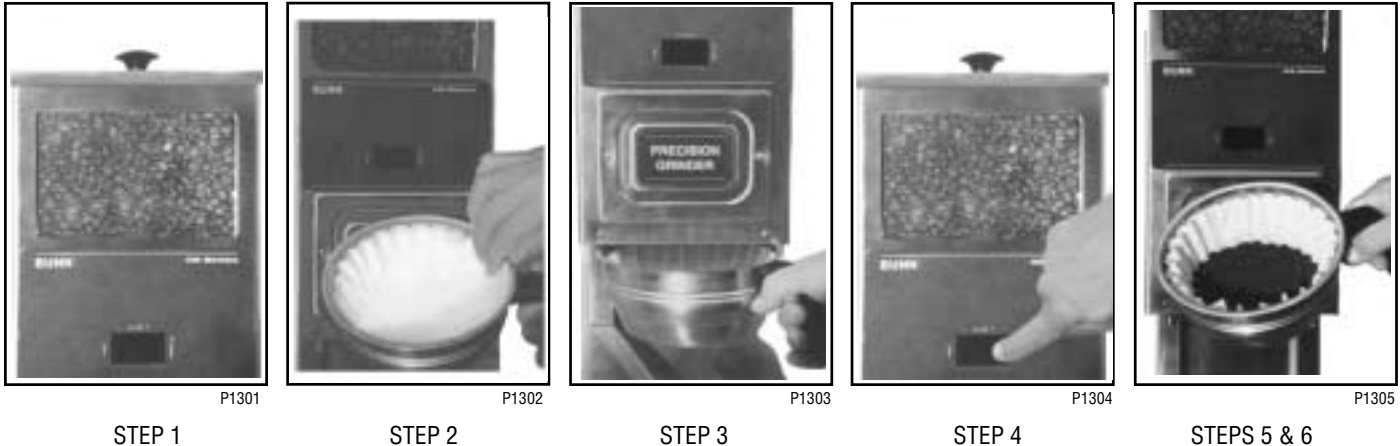

1. Visually inspect the hopper for an ample supply of whole bean coffee.
2. Place a paper filter into the brew funnel. The filter must not be folded-over or tilted to one side.
3. Insert the funnel into the funnel rails and push until it stops.
4. Momentarily place the switch in the “START” (right) position. The grinding action will stop automatically after the preset amount of ground coffee is dispensed into the funnel.
5. Remove the funnel from the grinder and level the bed of grounds by gently shaking.
6. The loaded funnel is now ready for use in any commercial drip coffee brewer according to the manufacturer’s instructions.

## ADJUSTMENTS

The grind can be set from very fine to very coarse. The amount may be adjusted for use in most commercial coffee brewers. The following procedures should be used to make adjustments. A change in the burr adjustment will also change the amount dispensed. Any adjustment of the burrs should be followed by an adjustment of the timer.

### Burr Adjustment

1. Unplug the grinder and empty all beans from the hopper.
2. Plug-in the grinder, momentarily place the Off/On/Start switch in the “START” (right) position, and run a few grind cycles until all of the coffee in the grind chamber is used-up.
3. Remove the upper front inspection panel.
4. Loosen the burr adjustment screw from its locked position.
5. Hand loosen the adjustment locking nut around the screw approximately one turn.
6. Place the Off/On/Start switch in the “START” (right) position and slowly turn the adjusting screw in a clockwise direction until a metallic whine is heard due to the rubbing of the grinding burrs. (It may be necessary to start more than one grind cycle to obtain this sound.)
7. Make a mark with a pen on the decal to note the position of the arrow on the grind adjustment screw.

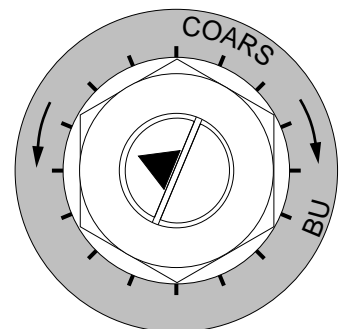

P581

## ADJUSTMENTS (cont.)

### Burr Adjustment (cont.)

- The following settings approximately correspond to the CBC recognized grinds. All are referenced from the arrow position noted in step 7.

**FINE GRIND:** Rotate the adjusting screw 7 hash marks in a counterclockwise direction.

**DRIP GRIND:** Rotate the adjusting screw 8 hash marks in a counterclockwise direction.

**REGULAR (COARSE) GRIND:** Rotate the adjusting screw 12 hash marks in a counterclockwise direction.

- Hold the adjusting screw in its set position with a screwdriver while tightening the lock nut to a snug position by hand. Slightly loosen the adjusting screw and retighten it to its prior position. The lock nut should now be tight against the burr housing front cover.

### Timer Adjustment

**NOTE:** Grinders with Multi Set option (Urn/Carafe) must be adjusted in both settings.

- Unplug the grinder and remove the lower front inspection panel.
- Determine the grind setting. (The factory setting is **drip**, to determine other settings, refer to the previous section.)
- Use the table below to find the approximate timer setting for the grind and amount of coffee desired.
- Set the timer for the desired amount of coffee to be ground.
- Verify the setting by weighing a few samples. **Use the table below as an APPROXIMATE guide only.**

### APPROXIMATE TIMER SETTINGS IN SECONDS

WEIGHT (OUNCES)	FINE (7*)	DRIP (8*)	REGULAR (12*)
1.5	2-2/3	2-1/3	2-1/3
1.75	3	2-2/3	2-2/3
2.0	3-2/3	3-1/3	3
2.25	4	3-2/3	3-1/3
2.5	4-1/3	4	3-2/3
2.75	4-2/3	4-1/3	4
3.0	5-1/3	5	4-1/3
3.25	6	5-1/3	5
3.5	6-1/3	5-2/3	5-1/3
3.75	6-2/3	6-1/3	5-2/3
4.0	7-1/3	6-2/3	6

\*Hash mark settings. Refer to *Adjustment-Burr* section.

## TROUBLESHOOTING

A troubleshooting guide is provided to suggest probable causes and remedies for the most likely problems encountered. If the problem remains after exhausting the troubleshooting steps, contact the Bunn-O-Matic Technical Service Department.

- Inspection, testing, and repair of electrical equipment should be performed only by qualified service personnel.
- All electronic components have 120 volt ac and low voltage dc potential on their terminals. Shorting of terminals or the application of external voltages may result in board failure.
- Intermittent operation of electronic circuit boards is unlikely. Board failure will normally be permanent. If an intermittent condition is encountered, the cause will likely be a switch contact or a loose connection at a terminal or crimp.
- Make certain that all electrical connections are tight and isolated.

## WARNING

- Exercise extreme caution when servicing electrical equipment.
- Turn power OFF when servicing, except when electrical tests are specified.
- Follow recommended service procedures.
- Replace all protective shields or safety notices.

<b>Problem</b>	<b>Probable Cause</b>	<b>Remedy</b>
Grinder will not start.	1. Motor overload protector	Remove the cover plate located on the right side of the housing. Press the red “Reset” button. Listen carefully for a “click”. This resets the motor protection circuit and indicates that an overload may have been encountered by the motor. (An overload can occur when something other than coffee is inserted into the hopper for grinding.) Refer to <i>Service - Motor</i> for disassembly procedures. See page 9.
	2. No power or incorrect voltage	Check the voltage at the power cord with a voltmeter. Voltage must be:  (A) 120 volts across the black and white wires for 120 volt models.  (B) 240 volts across the black and red/black wires for 240 volt models.
	3. Off/On/Start switch	(A) Momentarily place the switch in the “START” (right) position.  (B) Refer to <i>Service - Off/On/Start Switch</i> for testing procedures. See page 11.

## TROUBLESHOOTING (cont.)

<b>Problem</b>	<b>Probable Cause</b>	<b>Remedy</b>
Grinder will not start. (cont.)	4. Timer	Refer to <i>Service</i> - Timer for testing procedures. See page 13.
	5. Relay	Refer to <i>Service</i> - Relay for testing procedures. See page 12.
	6. Motor	Refer to <i>Service</i> - Motor for testing procedures. See page 9.
Grinder will not shut off.	1. Off/On/Start switch	(A) Place the switch in the "OFF" (left) position.  (B) Refer to <i>Service</i> - Off/On/Start Switch for testing procedures. See page 11.
	2. Timer	Refer to <i>Service</i> - Timer for testing procedures. See page 13.
	3. Relay	Refer to <i>Service</i> - Relay for testing procedures. See page 12.
Grinder starts, but will not dispense.	1. Hopper	Begin each grind cycle by visually inspecting the hopper for an ample supply of whole bean coffee.
	2. Bottom of hopper	Foreign materials must not block the opening at the bottom of the hopper.
	3. Shear plate	Refer to <i>Service</i> - Motor for replacement procedures. See page 9.
Incorrect amount of coffee.	1. Timer adjustment	Refer to the <i>Adjustments</i> section. See page 4.
Incorrect coffee grind dispensed.	1. Burr adjustment	Refer to the <i>Adjustments</i> section. See page 4.

## SERVICE

This section provides procedures for testing and replacing various major components used in this grinder should service become necessary. Refer to *Troubleshooting* for assistance in determining the cause of any problem.

**WARNING** - Inspection, testing, and repair of electrical equipment should be performed only by qualified service personnel. The grinder should be disconnected from the power supply when servicing, except when electrical tests are required and the test procedure specifically states to plug-in the grinder.

### Component Access

**WARNING** - Disconnect the grinder from the power supply before the removal of any panel or the replacement of any component.

All components are accessible by the removal of the upper and lower front inspection panels, top lid, rear panel, and hopper.

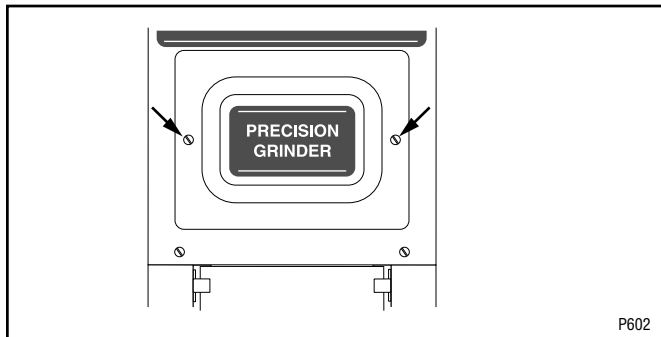

The upper front inspection panel is attached with two 6-32 screws.

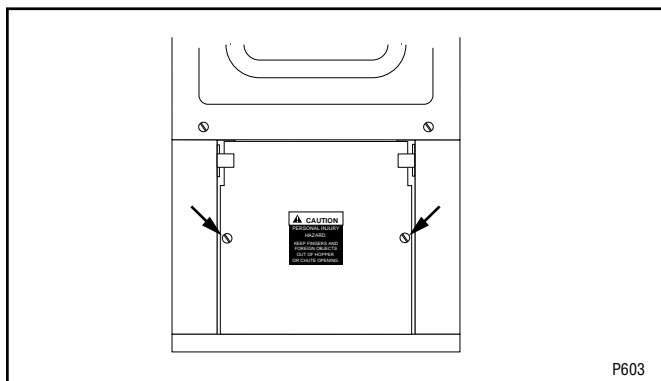

The lower front inspection panel is attached with two 6-32 screws.

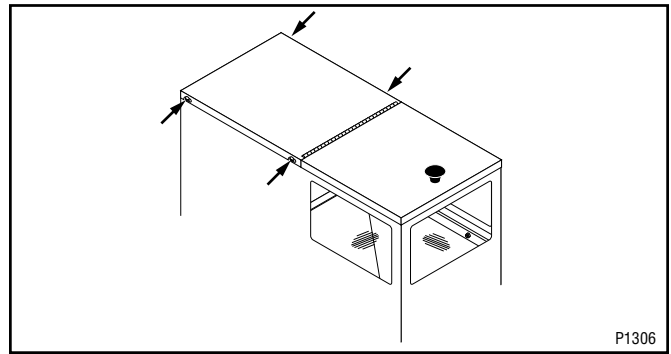

The top lid is attached with four 6-32 screws. These screws need only to be loosened for lid removal.

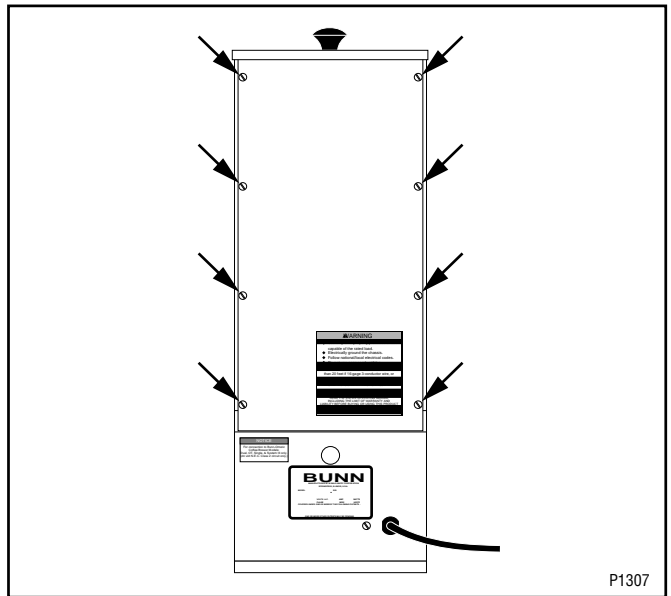

The rear panel is attached with eight 8-32 screws.

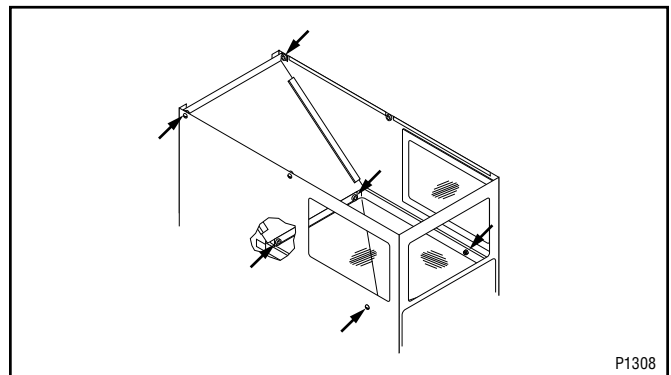

The hopper/extension assembly is attached with six 8-32 screws.

### Contents

Motor	9
Off/On/Start Switch	11
Urn/Caraffe Switch	11
Relay	12
Timer	13

## SERVICE (cont.)

### Motor

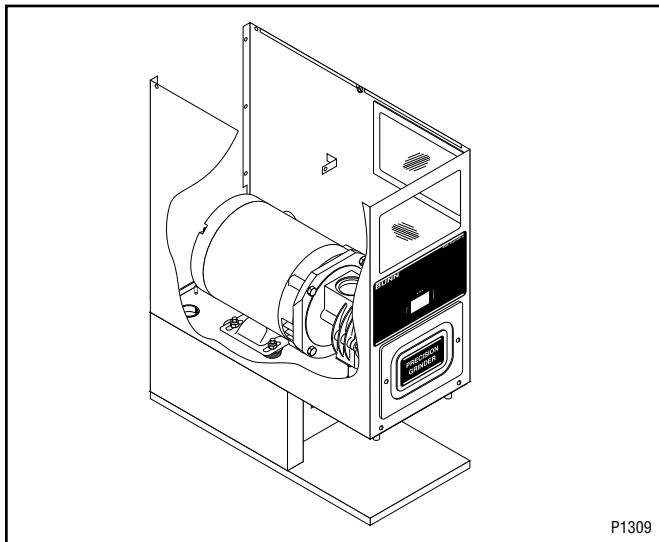

#### Location:

The motor is located in the upper wrapper under the hopper.

#### Test Procedure:

1. Remove the hole plug located on the right side of the housing. Press the red “Reset” button visible through the opening. Listen carefully for a “click”. This resets the motor protection circuit and may indicate that something other than coffee was inserted into the hopper for grinding.

If the grinder remains unable to start, proceed to step 2.

If the grinder stops operating shortly after starting, refer to the removal and replacement steps to gain access-to the grind chamber. Remove any foreign materials that may be found.

2. Disconnect the grinder from the power supply.
3. Remove the electrical access panel at the rear of the motor.
4. Check the voltage across terminals L1 & L2 of the motor with a voltmeter when the Off/On/Start switch is placed in the “START” (right) position and released. Connect the grinder to the power supply. The indication must be:
  - (a) 120 volts ac for two wire 120 volt models.
  - (b) 240 volts ac for two wire 240 volt models.
5. Disconnect the grinder from the power supply.

If voltage is present as described and the grinder remains unable to start, replace the motor.

If voltage is not present as described, refer to the *Wiring Diagrams*, and check the grinder wiring harness.

#### Removal and Replacement - MOTOR

1. Remove all wires from the Off/On/Start switch, motor, and motor mounting plate.
2. The entire wiring harness must be fed into the bottom of the grinder housing through the hole in the motor mounting plate.
3. Remove both 6-32 screws beneath the upper front inspection panel.
4. Remove the six 10-32, hex head screws on top of the motor mounting plate.
5. Slowly slide the assembly out the rear of the grinder housing. The mounting plate will have to be raised to gain clearance for the motor hardware and wiring harness bushing.
6. Remove the four 5/16"-18 bolts and nuts to separate the motor from the mounting plate.
7. Mount the new motor and tighten the four bolts and nuts. They should be tightened approximately one full turn past snug.
8. Slide the motor mounting plate into the rear of the grinder housing.
9. Feed the wiring harness into the top of the housing through the hole in the motor plate.
10. Reinstall the six 10-32 hex head screws through the motor plate and the two 6-32 screws through the housing.
11. Reattach the green wire to the 10-32 stud on the motor mounting plate.
12. Refer to the *Off/On/Start switch* section when reconnecting the switch wires.
13. Refer to the illustration below when reconnecting the motor wires.

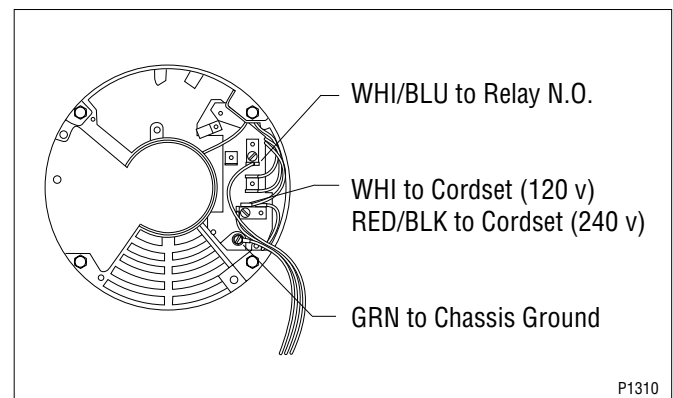

## SERVICE (cont.)

### Motor (cont.)

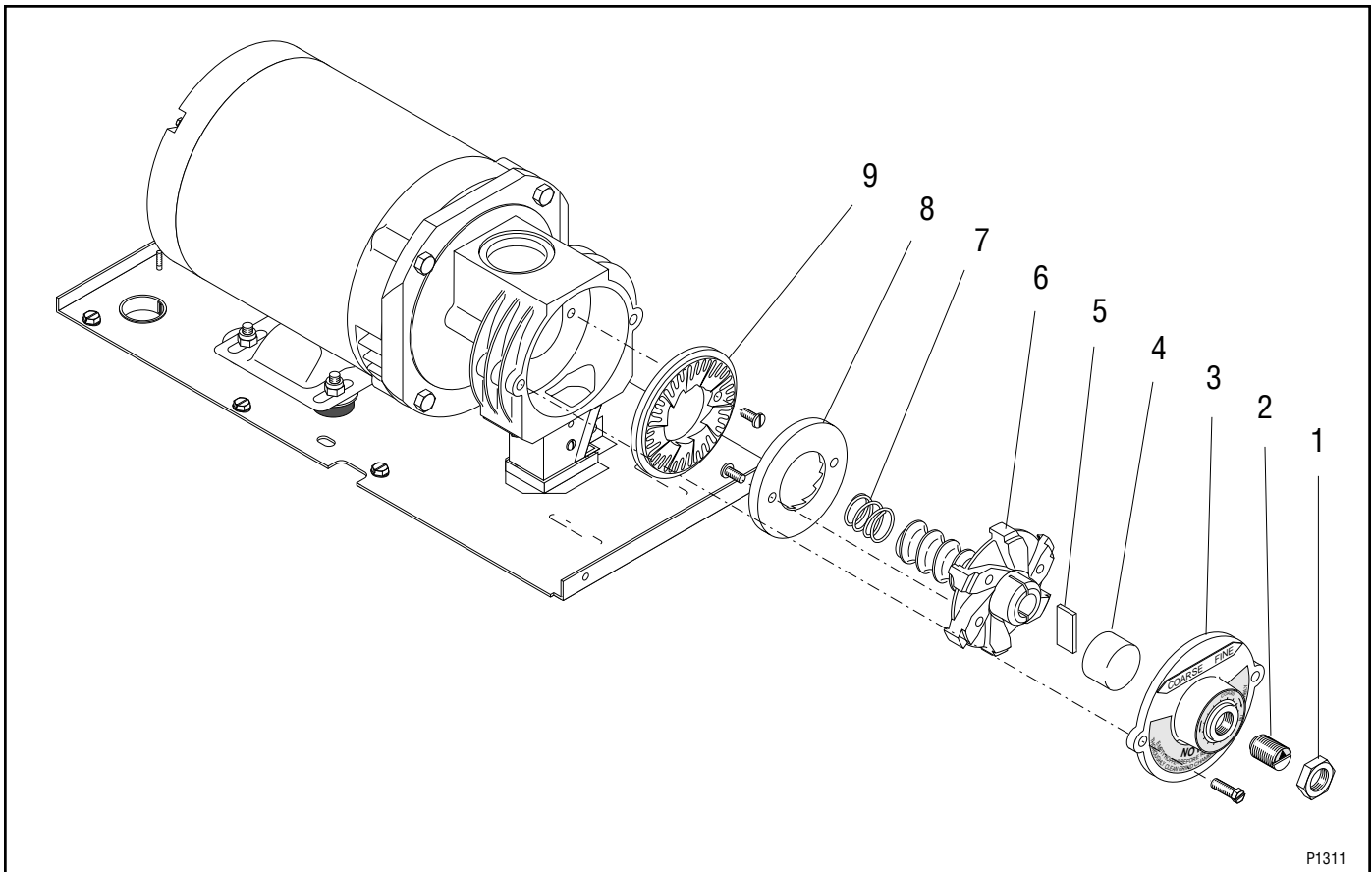

P1311

- |                            |                      |
|----------------------------|----------------------|
| 1. Adjusting Screw Locknut | 6. Rotor             |
| 2. Adjusting Screw         | 7. Spring            |
| 3. Burr Housing Cap        | 8. Burr (Rotating)   |
| 4. Rotor Cup               | 9. Burr (Stationary) |
| 5. Shear Plate             |                      |

#### Removal and Replacement - GRIND CHAMBER

1. Refer to the illustration above and remove the two 1/4"-20, hex head screws holding the burr housing cap(3) to the burr housing; carefully remove the burr housing cap. Inspect the adjusting screw(2) to see if the thrust plug is worn.  
**Replace if excessively worn or damaged.**
2. Carefully remove rotor cup(4), shear plate(5), and burr rotor(6) from the grinder. Inspect the shear plate and burr(8) for wear.  
**Replace if excessively worn or damaged.**
3. Remove and inspect stationary burr(9) for wear.  
**Replace if excessively worn or damaged.**
4. Inspect the grind chamber and remove any foreign materials. The burrs will not properly seat in the chamber if any material or coffee particles remain.
5. Reinstall the stationary burr, spring, burr rotor, shear plate, rotor cup, and burr housing cap to the burr housing.
6. Refer to the *Adjustments* section to vary the grind dispensed.

**NOTE: Burrs must be replaced as a set.**

## SERVICE (cont.)

### Off/On/Start Switch

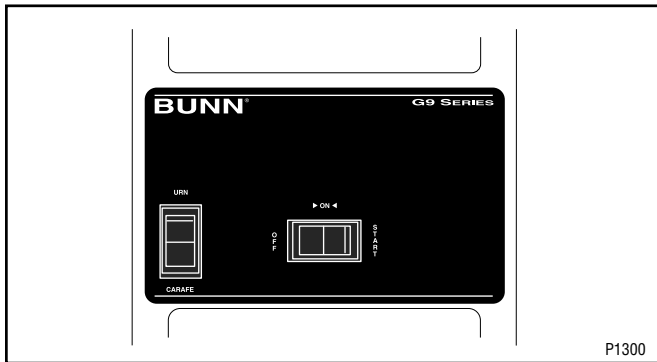

#### Location:

The Off/On/Start switch is centered in the housing above the upper front inspection panel.

#### Test Procedure:

1. Disconnect the grinder from the power supply.
2. Remove the black wire from the switch.
3. Check for continuity across the black wire from the Off/On/Start switch and the left blade of the cordset connector (see illustration below).

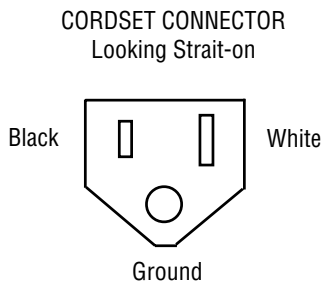

If continuity is present as described, proceed to step 4.

If continuity is not present as described, refer to the Wiring Diagrams and check the grinder wiring harness.

4. Remove the remaining wires from the switch.
5. Check for continuity across the lower terminals when the switch is placed in both the "ON" (center) and "START" (right) positions.

If continuity is present as described, proceed to step 6.

If continuity is not present as described, replace the switch.

6. Check for continuity across the upper terminals when the switch is placed in the "START" (right) position only.

If continuity is present as described, the Off/On/Start switch is operating properly.

If continuity is not present as described, replace the switch.

#### Removal and Replacement:

1. Remove all wires from the switch terminals.
2. Compress the clips inside the front wrapper and gently push the switch through the opening.
3. Push the new switch into the opening and spread the clips to hold the switch captive in the hood.
4. Refer to the illustration below when reconnecting the wires.

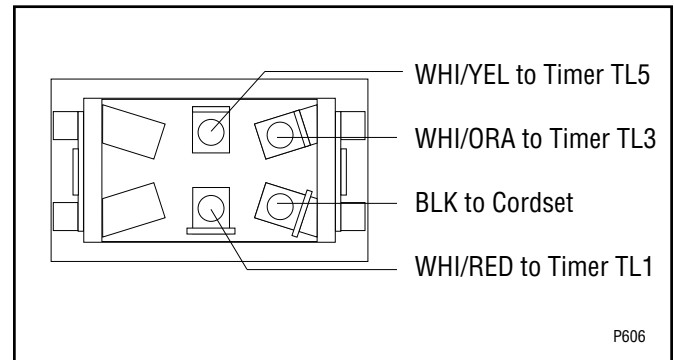

### Urn/Carafe Switch

#### Location:

The Urn/Carafe switch is located to the left side on the front of the housing above the upper inspection panel.

#### Test Procedure:

1. Disconnect the grinder from the power supply.
2. Remove the tan, yellow and green wires from the switch.
3. Place the switch in the "CARAFE" position; check for continuity across the pink and the tan wire terminals, also across the orange and the yellow wire terminals.

If continuity is present as described in both checks, proceed to step 4.

If continuity is not present as described in one or both of the checks, replace the switch.

4. Place the switch in the "URN" position; check for continuity across the orange and green wire terminals.

If continuity is present as described, the switch is operating properly.

## SERVICE (cont.)

If continuity is not present as described, replace the switch.

### Removal and Replacement:

1. Remove all the wires from the switch terminals.
2. Compress the clips inside the housing and gently push the switch through the opening.
3. Push the new switch into the opening and spread the clips to hold the switch in the housing.
4. Refer to the illustration below when reconnecting the wires.

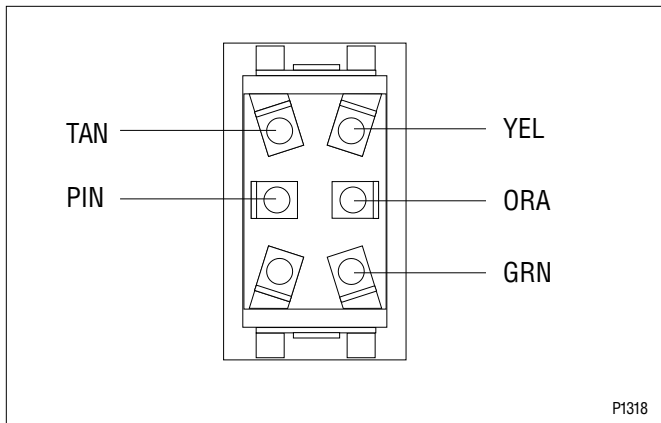

## Relay

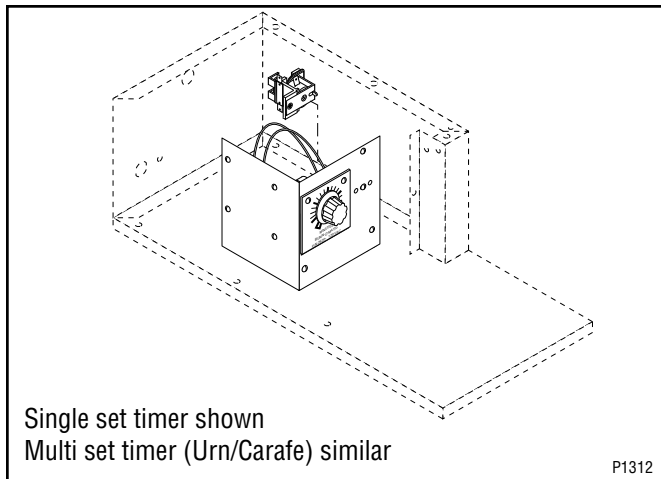

### Location:

The relay is located on the timer bracket in the grinder base. The bracket can be removed by loosening the two 8-32 screws beneath the timer dial.

### Test Procedure:

1. Disconnect the grinder from the power supply.
2. Check the voltage across the white/red and white/

green wires of the relay coil with a voltmeter when the Off/On/Start switch is placed in the "START" (right) position and released. Connect grinder to the power supply. The indication must be:  
(a) 120 volts ac for two wire 120 volt models  
(b) 240 volts ac for two wire 240 volt models for the approximate setting on the timer.

3. Disconnect the grinder from the power supply.

If voltage is present as described, reconnect the white/red and white/green wires to the relay coil, and proceed to step 4.

If voltage is not present as described, refer to the *Wiring Diagrams* and check the grinder wiring harness.

4. Remove the white/red and white/blue wires from the relay contacts.
5. Check for continuity across the relay contacts when the Off/On/Start switch is placed in the "START" (right) position and released. Connect grinder to the power supply. Continuity must be present for the approximate setting on the timer.
6. Disconnect the grinder from the power supply.

If continuity is present as described, reconnect the white/red and white/blue wires, the relay is operating properly.

If continuity is not present as described, replace the relay.

### Removal and Replacement

1. Remove all wires from the relay terminals.
2. Remove the 6-32 screw fastening the relay to the timer bracket.
3. Mount the new relay to the timer bracket and tighten the screw.
4. Refer to the illustration below when reconnecting the wires.

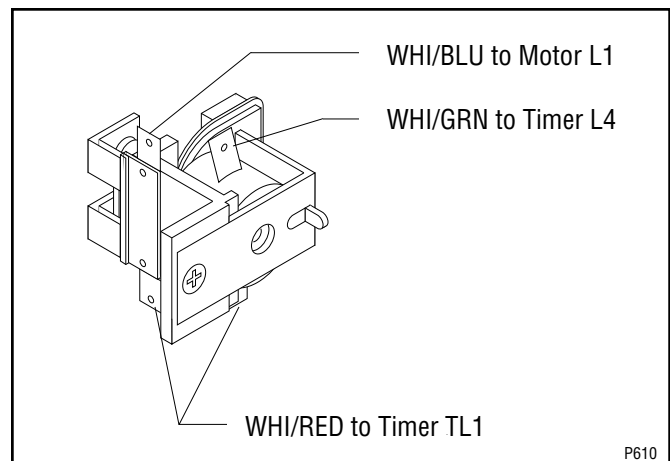

## SERVICE (cont.)

### Timer

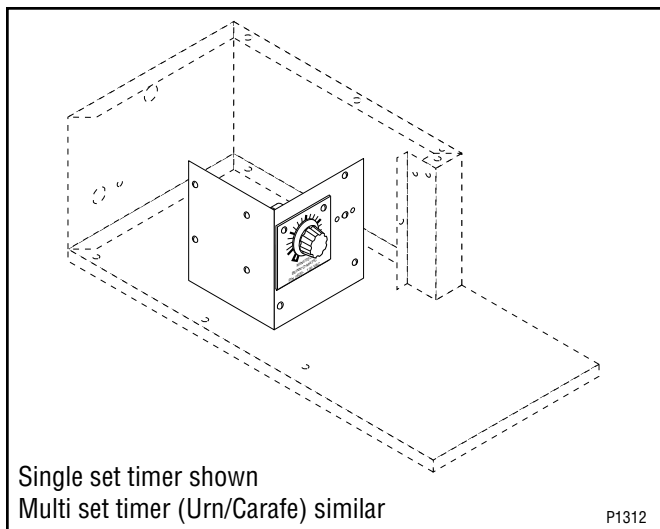

#### Location:

The timer is located on the timer bracket in the grinder base. The bracket can be removed by loosening the two 8-32 screws beneath the timer dial(s).

#### Test Procedure:

1. Disconnect the grinder from the power supply.
2. Check the voltage across terminals TL1 & TL2 with a voltmeter when the "Off/On/Start switch is placed in the "START" (right) position and released. Connect grinder to the power supply. The indication must be:  
(a) 120 volts ac for two wire 120 volt models.  
(b) 240 volts ac for two wire 240 volt models.
3. Disconnect the grinder from the power supply.

If voltage is present as described, proceed to step 4.

If voltage is not present as described, refer to the *Wiring Diagram* and check the grinder wiring harness.

4. Remove the white/orange and white/yellow wires from terminals TL3 & TL5.
5. Check for continuity across the white/orange and white/yellow wires when the Off/On/Start switch is placed in the "START" (right) position.

If continuity is present as described, reconnect the white/orange wire to terminal TL3 and the white/yellow wire to terminal TL5, and proceed to step 6.

If continuity is not present as described, refer to the *Wiring Diagram* and check the grinder wiring harness.

6. Check the voltage across terminals TL1 and TL4 with a voltmeter when the Off/On/Start switch is placed in the "START" (right) position and released. Connect grinder to the power supply. The indication must be:  
(a) 120 volts ac for two wire 120 volt models.  
(b) 240 volts ac for two wire 240 volt models.
7. Disconnect the grinder from the power supply.

If voltage is present as described, the timer is operating properly. Refer to the *Adjustments* section to vary the amount dispensed.

If voltage is not present as described, replace the timer.

#### Removal and Replacement:

1. Remove all wires from the timer terminals.
2. Remove the four 6-32 screws and nuts holding the circuit board to the timer bracket.
3. Remove the two 6-32 screws and nuts holding the dial plate to the timer bracket.
4. Install the new dial plate and circuit board to the timer bracket.
5. Refer to the illustration below when reconnecting the wires.
6. Refer to the *Adjustments* section to vary the amount dispensed.

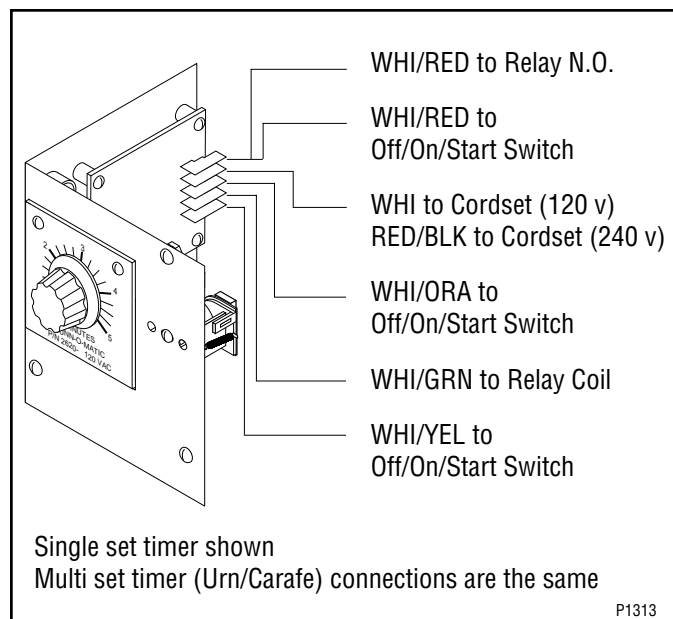

# WIRING DIAGRAM

## SCHEMATIC WIRING DIAGRAM G9

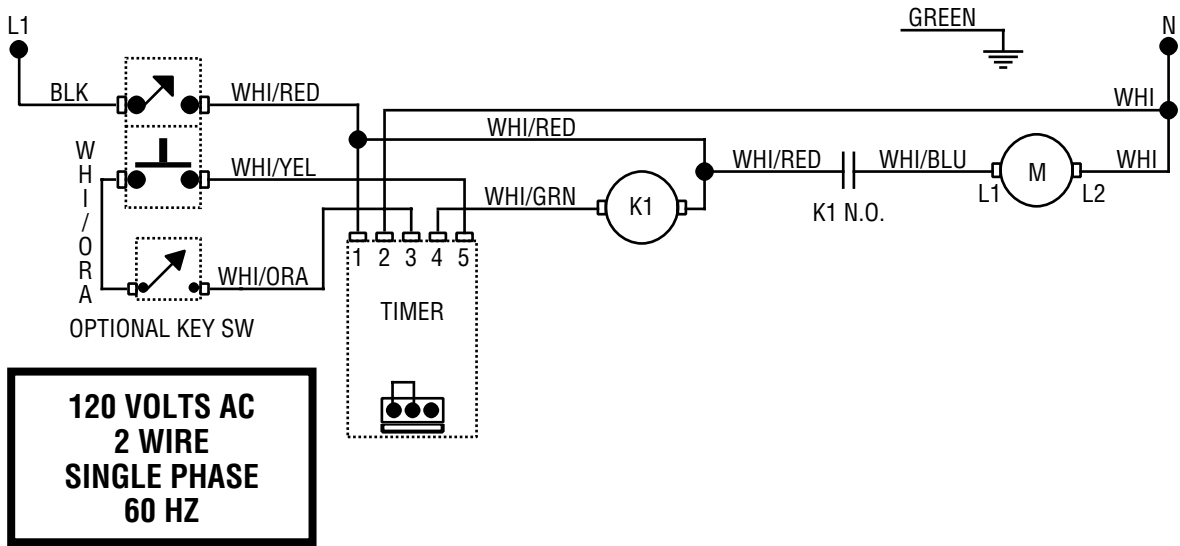

## SCHEMATIC WIRING DIAGRAM G9-URN/CARAFE

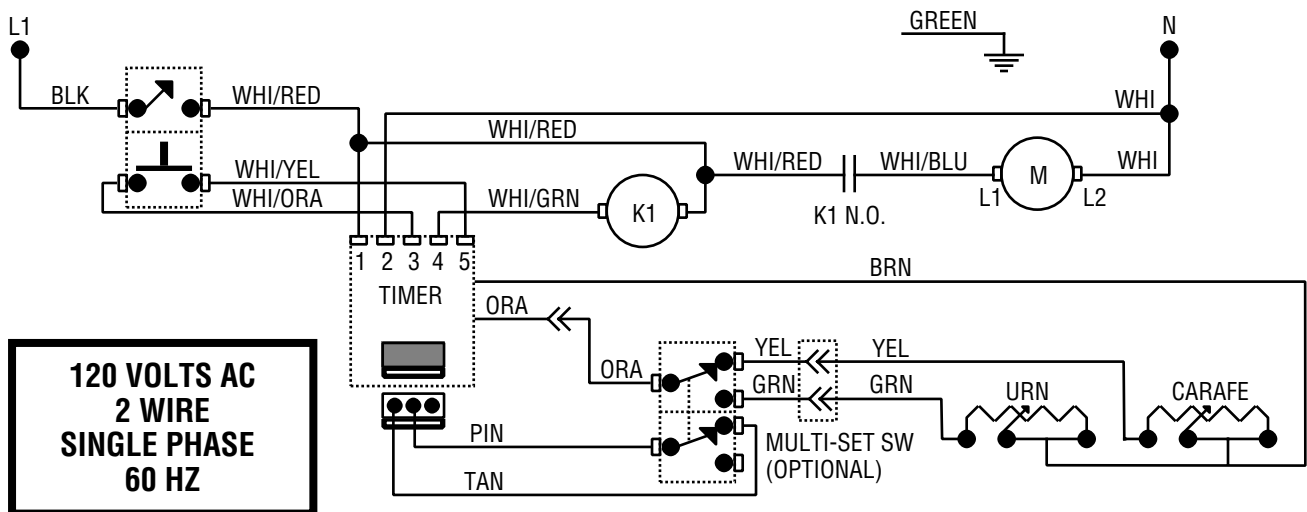

# SCHEMATIC WIRING DIAGRAM G9A HD

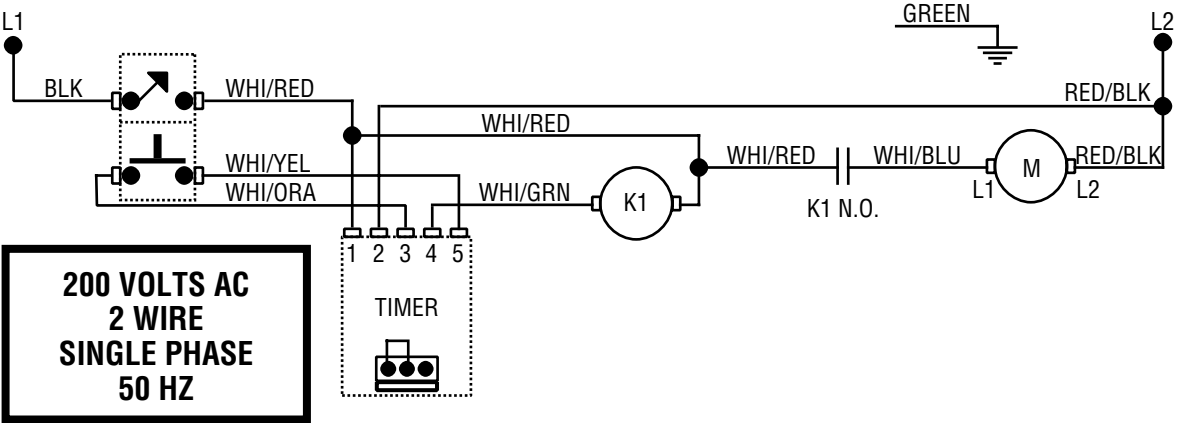

# SCHEMATIC WIRING DIAGRAM G9A HD

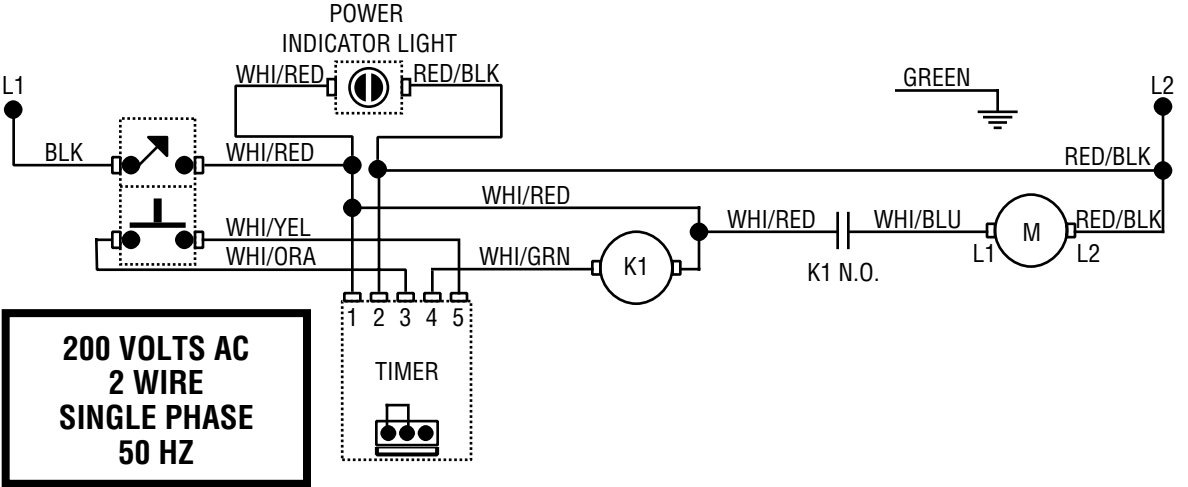

# WIRING DIAGRAM

## SCHEMATIC WIRING DIAGRAM G9

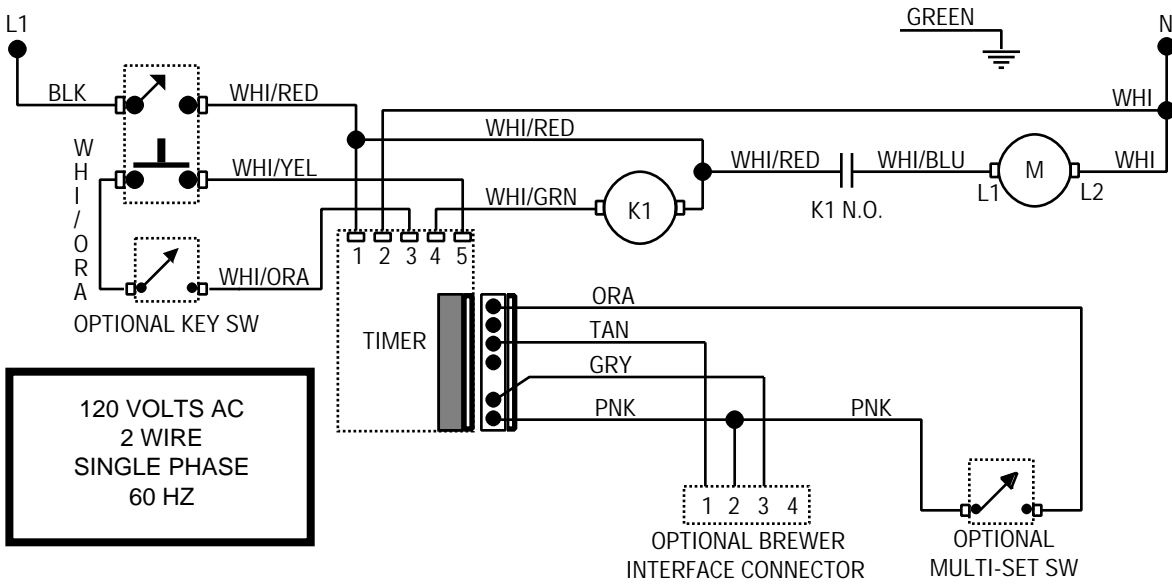

## SCHEMATIC WIRING DIAGRAM G9

